

PHAROS: MODEL SPECIFICATIONS

TECHNICAL DATA	2
INSTALLATION	3
OPERATE THE PHAROS	5
SAFETY RULES	8
CERTIFICATION	9

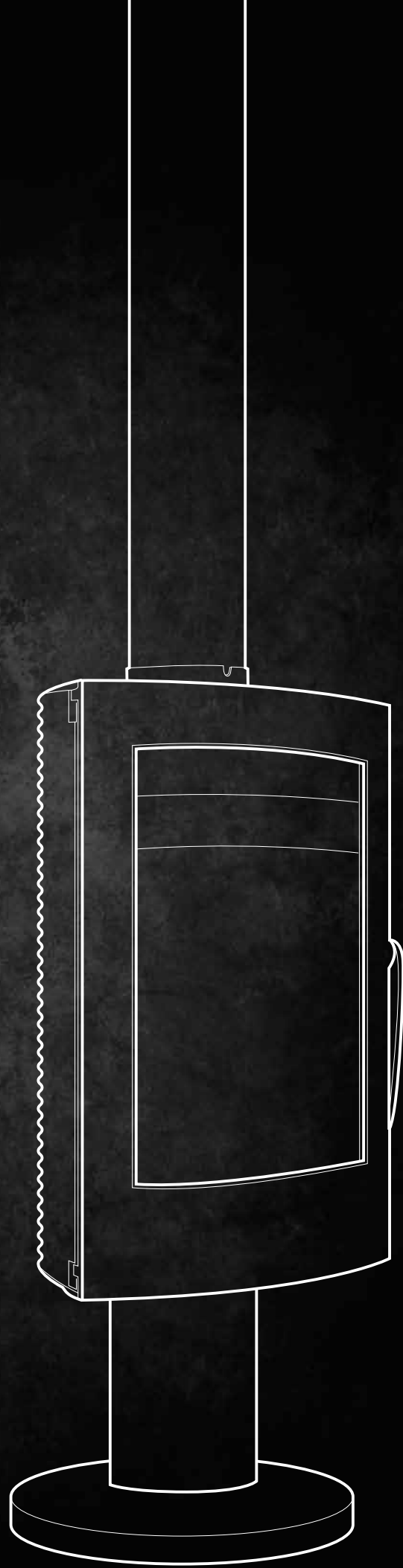

TECHNICAL DATA

Please read this notice carefully.

	AUSTRALIAN STANDARDS TEST RESULTS	MANUFACTURER DATA
Power output	11kW	12kW
Efficiency	56%	76%
Weight	167.5 Kg	
Dimensions	h1250mm Ø530mm	
Flue sections	Double skin 175/225mm	
Roof/ceiling penetration	Triple skin 275mm	
Fuel	Wood / 400mm long log max (or 500mm upright)	
Modes of use	Ignition / Normal rate / Slow Combustion	

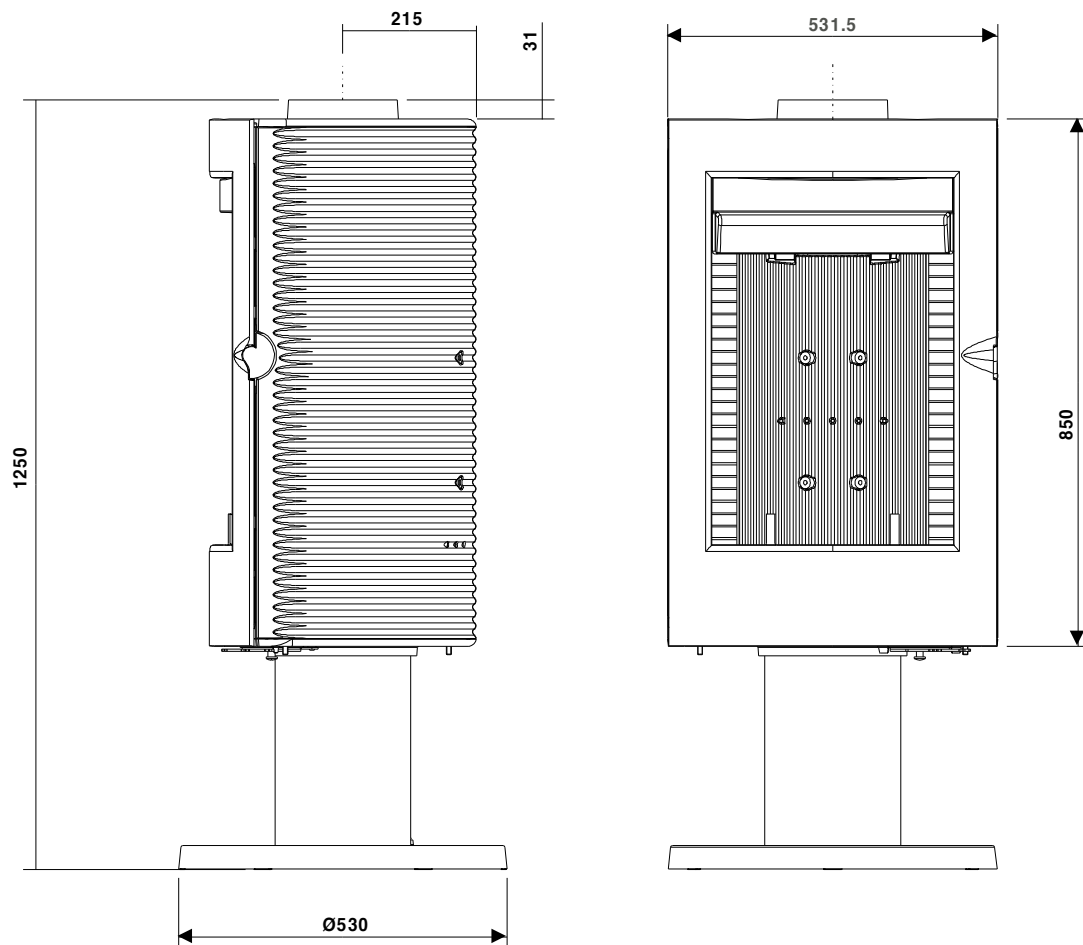

INSTALLATION

CLEARANCES AND FLOOR PROTECTOR

Clearances and Floor Protector

If the Pharos stove is to be installed near combustible surfaces, it is necessary to respect the minimum distances indicated in the diagram below.

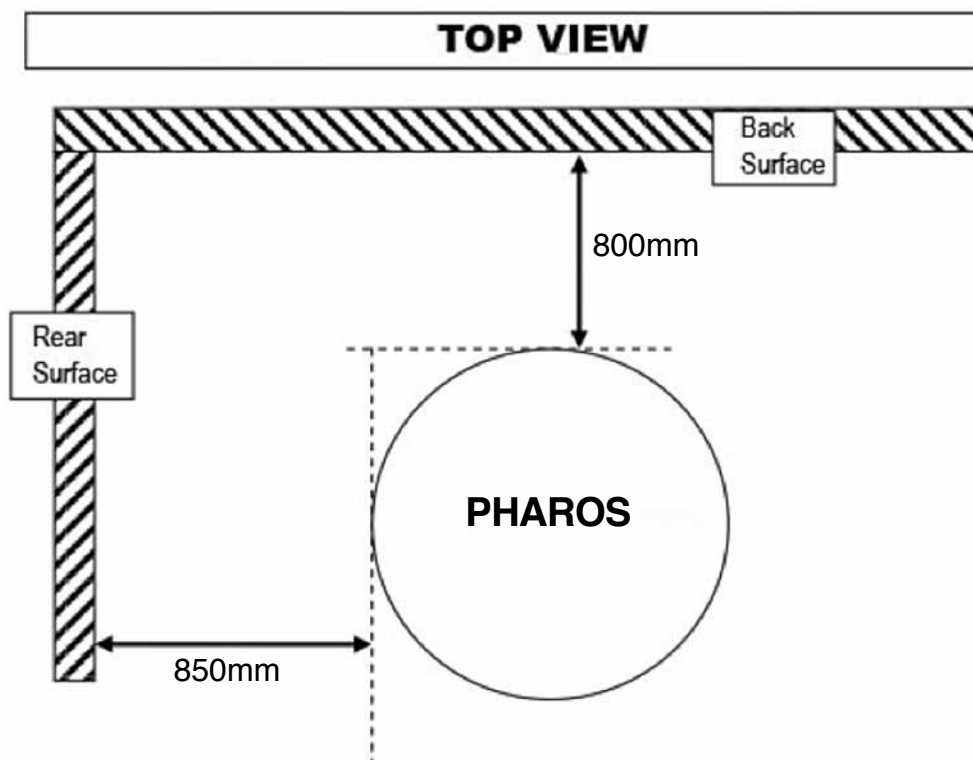

It is possible to reduce these clearances by installing heat shields between the unit and the combustible material. Installation of such heat shields has to be made in accordance with the BCA (Building Code of Australia)

If the nearby surfaces are **made of incombustible materials** and do not get damaged under heat, those clearances may be reduced to **100mm** (as per BCA regulation).

Floor Protector.

If the Pharos is to be installed on top of a combustible surface (e.g. Timber floor), a floor protector **must be placed** directly underneath the Pharos.

The floor protector shall be made of heat resistant material (e.g. steel, cement sheet, tiles, glass...) and shall extend not less than 300mm from the front and 200mm from the side of the base.

INSTALLATION

DEFLECTOR ASSEMBLY

To avoid any damage during transport the deflector is attached to the grids. The deflector must be put in place before use of the fireplace.

**STEP
1**

Cut the tie keeping the deflector to the grids and bring it to the top of combustion chamber (indicator no. 1 on sketch below)

**STEP
2**

Place bottom of the deflector on the rear stops (indicator no. 2 on sketch).

**STEP
3**

Let the front of the deflector sit on the front stops (indicator no. 3 on sketch).

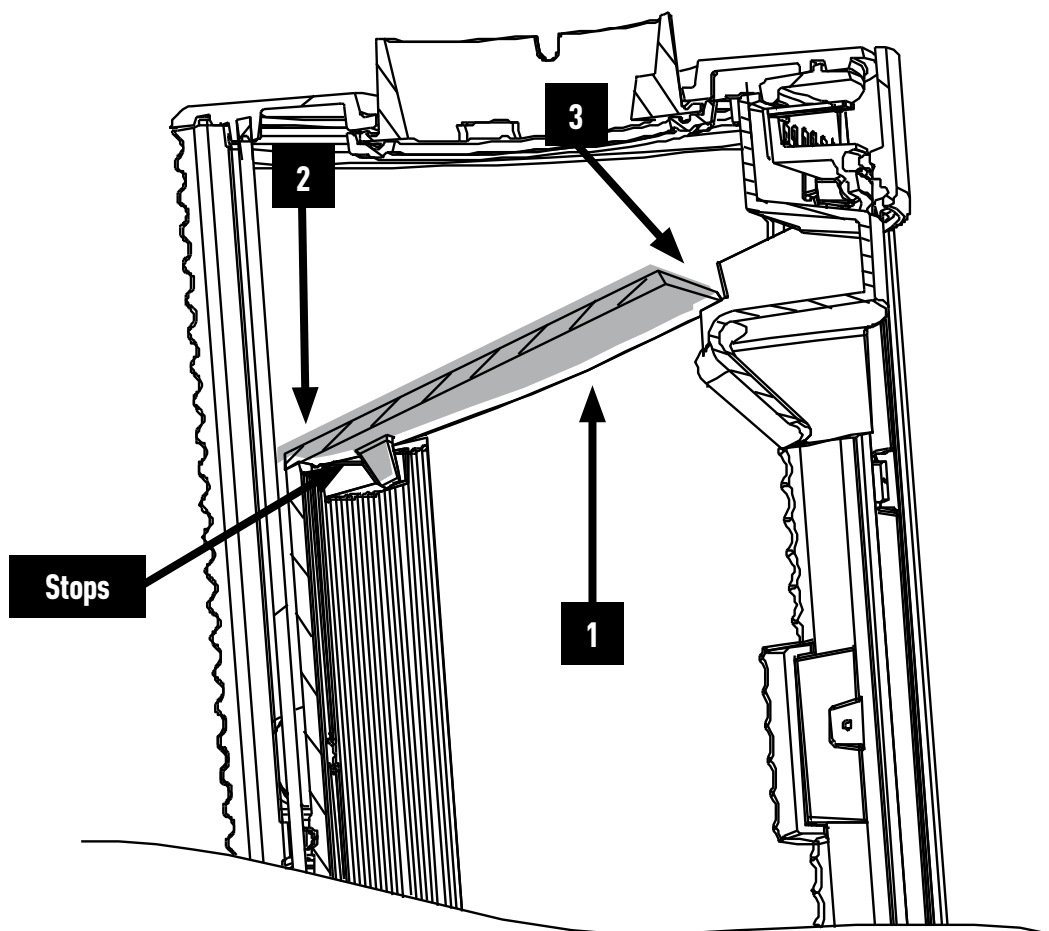

OPERATE THE PHAROS

FUEL

Only use recommended Fuel. Dry wood (Less than 20% moisture content) or at least 2 years old cut. Avoid soft wood, painted or treated timber.

The ash pit drawer must always remain in the appliance during de-ashing. To open or close the door, use a heat resistant glove.

Verification before operating the first times

During the first operations of the appliance a smell of paint evaporates from the appliance. Ventilate the room to limit nuisance.

AIR CONTROL

Use the heat resistant glove provided with the appliance to handle the instruments of control, which could be very hot.

Burning rates

Located on the front of the ash pit, this damper is used to regulate the rate of this appliance between "Ignition", "normal rate" and "slow combustion".

WARNING: Putting the damper on "ignition" position allows an addition of air intake. This position is to be used only for ignition and must be maintained **no more than 30 minutes** to avoid overheating damage. The appliance must be attended during the whole duration of operation in this position.

OPERATE THE PHAROS

MODES OF USE

3 modes of use: Ignition, Normal Rate and Slow Combustion.

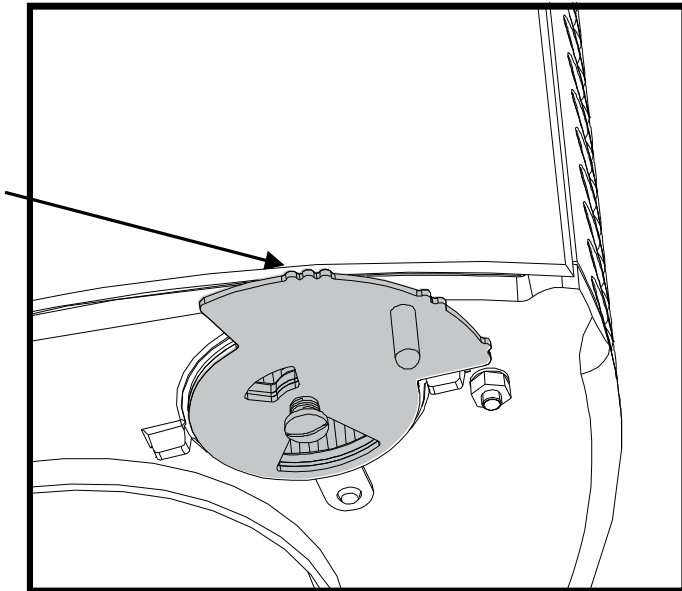

Ignition

Place some crushed paper on the grid (avoid glazed paper) and some kindlings. Lit the paper, close the door of the appliance and fully open the air outlet. Once the fire is well lit up you can load your appliance. It is recommended, during the first hours of operation, to make a moderate fire so as to allow a normal dilatation of the whole appliance. To ease ignition, we advise you to keep a bed of ashes on the grid, which will be saved for further use (make sure air vents aren't obstructed too much).

WARNING: Ignition position only to be used during ignition (30 min max).

The appliance must be attended during the whole duration of operation in this position!

OPERATE THE PHAROS

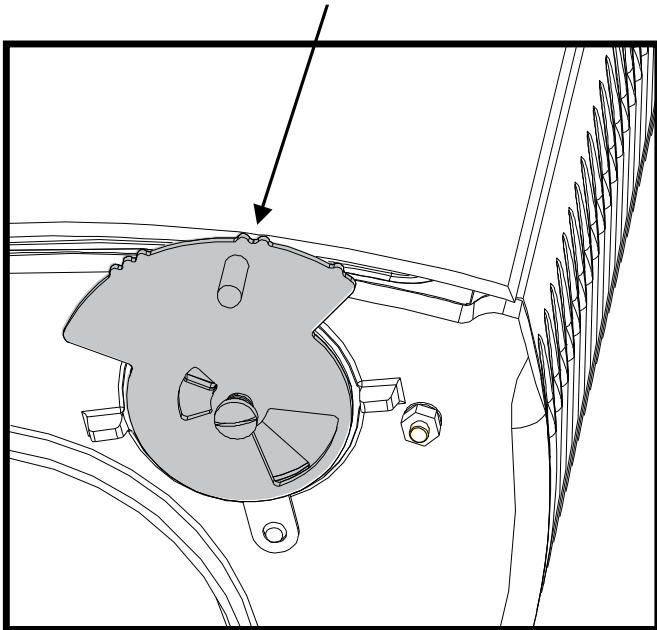

Normal Rate

An “intermittent” operation requires reloading every 3/4 of an hour with small quantities of wood. This mode of operation is a preferred mode as it performs particularly well and is eco-friendly. The appliance can also operate under “continuous” when the constraints of intermittence cannot be respected or a reduced power is chosen. In this case, full power can be achieved over duration of 3 hours, and at a reduced rate, at low power, 10 hours of operation are achievable.

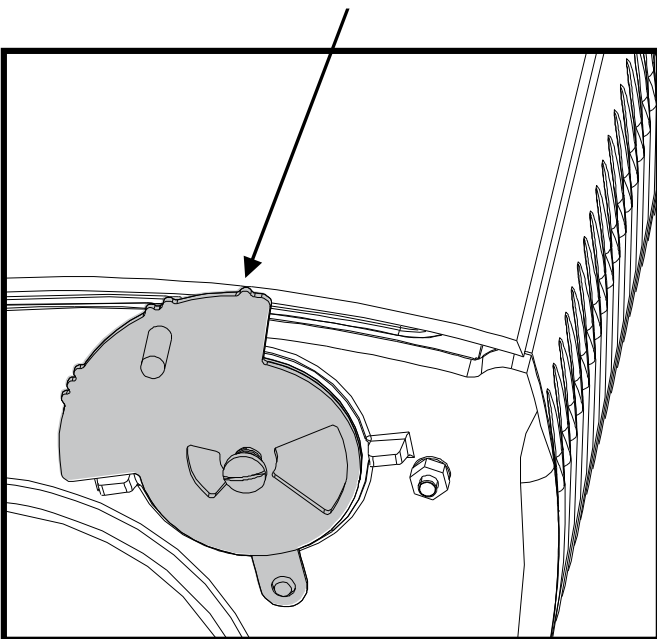

Slow combustion

This combustion is achieved under a draft of 6Pa with a 6 to 8 kg load of large hard un-split wood and by totally shutting the heat control. First carry out a reduced heat control regime by shutting the heat control and then load over a very low reddish ember bed.

SAFETY RULES

Flammable objects must be kept at a minimum of 1.5 meters from the stove. In particular clothing or objects that may be put near the stove to dry.

During operation, all the stove's surfaces are hot: Be careful of burns!!!

Never try to modify the stove.

The use of fuels that are not recommended or unsuitable for the stove are forbidden, including liquid fuels.

The combustion chamber must always remain closed, except during reloading and removing ash.

Never overheat the stove.

Using the stove as an incinerator is forbidden.

CERTIFICATION

AS/NZS STANDARDS

The Pharos has been Tested and Approved under AS/NZS standards as per below:

LABORATORY:

VIPAC Engineers & Scientist
279 Normanby Rd, Port Melbourne VIC 3207
(03) 9647 9700

VIPAC is a NATA accredited Laboratory.
Registration Number: 676.

TITLE:

Oblica — Pharos wood heater

WORK REQUESTED:

Assessment of appliance to AS/NZS 4012:1999 for determination of Power Output and Efficiency and AS/NZS 4013:1999 for Flue Gas Emission using hardwood fuel.

Assessment of appliance in one configuration to AS/NZS 2918:2001 Appendix B, with a full-length standard flue kit.

TEST DATE:

16/02/2012 to 08/03/2012.

TEST REPORT NUMBER:

30A-12-0012-TRP-257791-0
30A-12-0012-TRP-257790-0

INVESTIGATING OFFICERS:

Rhys Connick, Rebecca Searcy.